

CAST STEEL GLOBE VALVES BS-1873 / ASME B16.34

Bolted Bonnet Os & Yoke Type, Rising Stem, Flanged/butt Weld Ends

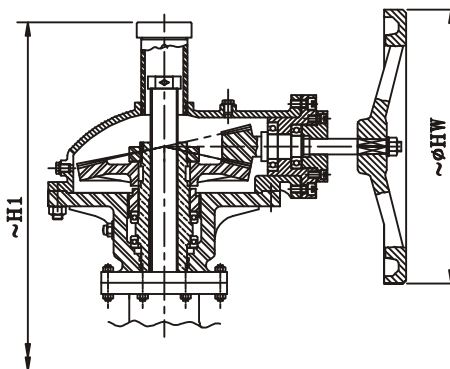
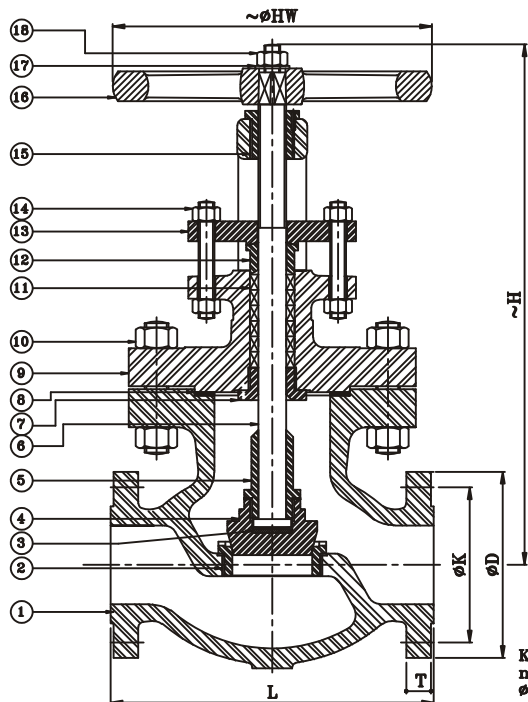

NOTE:

- (1) CLASS 150 & 300 FLANGES ARE FURNISHED WITH 2mm RAISED FACE (f)
- (2) CLASS 600 & ABOVE FLANGES ARE FURNISHED WITH 7mm RAISED FACE (f) WHICH IS ADDITIONAL TO THE FLANGE THICKNESS (T)
- (3) BUTT WELD ENDS AS PER ANSI B: 16.25.



K=PCD
n=No. OF HOLES
ød=DIA. OF HOLES

STANDARD MATERIAL COMBINATION

P. No	PART NAME	Carbon steel to ASTM		Alloy steel to ASTM					Stainless steel to ASTM			
		Type WCB	Type LCB	Type WC1	Type WC6	Type WC9	Type C5	Type C12	Type CF8	Type CF8M	Type CF3	Type CF3M
1	BODY	A216 WCB	A352 LCB	A217 WC1	A217 WC6	A217 WC9	A217 C5	A217 C12	A351 CF8	A351 CF8M	A351 CF3	A351 CF3M
2	BODY SEAT RING	As per Trim Material Combination										
3	THRUST PLATE	HARDENED STEEL										
4	DISC	As per Trim Material Combination										
5	DISC NUT	A182 F6a	F304	A182 F6a	A182 F6a	A182 F6a	A182 F6a	A182 F6a	A276 F304	A182 F316	A182 304L	A182 316L
6	STEM	As per Trim Material Combination										
7	BACK SEAT BUSH	As per Trim Material Combination										
8	GASKET	Spiral wound Stainless steel Graphoil filled										
9	BONNET	A216 WCB	A352 LCB	A217 Wc1	A217 WC6	A217 WC9	A217 C5	A217 C12	A315 CF8	A351 CF8M	A351 CF3	A351 CF3M
10	BODY BONNET STUDS & NUTS	A193 B7 A194 2H	A320 L7 A194 4	A193 B7 A194 2H	A193 B16 A194 4	A193 B16 A194 4	A193 B16 A194 4	A193 B16 A194 4	A193 B8 A194 8	A193 B8 A194 8M	A193 B8 A194 8	A193 B8 A194 8M
11	PACKING	To Suit service conditions										
12	GLAND	A182 F6a	A182 F6a	A182 F6a	A182 F6a	A182 F6a	A182 F6a	A182 F6a	A276 F304	A182 F316	A182 304L	A182 316L
13	GLAND FLANGE	A105	A350 LF2	A105	A105	A105	A105	A105	A351 CF8	A351 CF8M	A351 CF3	A351 CF3M
14	STUDS & NUTS	A193 B7 A194 2H	A320 L7 A194 Gr.4	A193 B7 A194 2H	A193 B16 A194 Gr.4	A193 B16 A194 Gr.4	A193 B16 A194 Gr.4	A193 B16 A194 Gr.4	A193 B8 A194 Gr.8	A193 B8 A194 Gr.8	A193 B8 A194 Gr.8	A193 B8 A194 Gr.8
15	YOKE BUSH	Al. Bronze BS 1982 CC331G or Ni-resist to A4390D2										
16	HANDWHEEL	DI A536 80-55-06 OR MI 1S2108 BM290/ASTMA338										
17	WASHER	STEEL										
18	HANDWHEEL RETAINING NUT	STEEL										

NOTE: The above data is subject to change without notice due to our continuing product improvement program.



CAST STEEL GLOBE VALVES BS-1873 / ASME B16.34

TRIM MATERIAL COMBINATION (ON REQUEST)

Trim No.	Seat Ring Face	Wedge Seat Face	Stem	Backseat Bush	Lantern Ring
1	F6a/13%Cr.	F6a/13%Cr.	F6a/AISI410	F6a/AISI410	F6a/AISI410
2	F304	F304	F304/AISI304	F304/AISI304	F304/AISI304
5	STELLITE	STELLITE	F6a/AISI410	F6a/AISI410	F6a/AISI410
8	STELLITE	F6a/13%Cr.	F6a/AISI410	F6a/AISI410	F6a/AISI410
9	MONEL	MONEL	MONEL	MONEL	MONEL
10	F316	F316	F316/AISI316	F316/AISI316	F316/AISI316
12	316+STELLITE	316	F316/AISI316	F316/AISI316	F316/AISI316
13	ALLOY 20	ALLOY 20	ALLOY 20	ALLOY 20	ALLOY 20

NOTE: Other Trim Combination can be given.

DIMENSIONAL DATA CLASS-150

•All dimensions in mm

DN	40	50	65	80	100	125	150	200	250	300*	350*	400*	500*
NPS	1 ½	2	2 ½	3	4	5	6	8	10	12	14	16	20
L	165	203	216	241	292	356	406	495	622	698	787	914	978
L1	165	203	216	241	292	356	406	495	622	698	787	914	978
L2	178	216	229	254	305	369	419	508	635	711	800	927	991
fD	125	150	180	190	230	255	280	345	405	485	535	595	700
T	12.7	14.3	15.9	17.5	22.3	22.3	23.9	27	28.6	30.2	33.4	35	41.3
K(PCD)	98.5	120.7	139.7	152.4	190.5	215.9	241.3	298.5	361.9	431.8	476.3	539.8	635
n	04	04	04	04	08	08	08	08	12	12	12	16	20
kd	15.7	19.1	19.1	19.1	19.1	22.3	22.3	22.3	25.4	25.4	28.6	28.6	32
~H(Close)	295	330	422	445	490	570	600	642	770	825	1180	1220	2085
~H(Open)	305	343	438	465	515	601	638	692	833	900	1268	1320	2210
~H1	-	-	-	-	-	-	-	-	-	1112	-	1220	1941
kHW	203	203	229	229	254	254	304	457	559	635	450	450	700
Aprox.wt.â	16.5	25.5	35	44	77	102	126	220	337	564	803	851	---

DIMENSIONAL DATA CLASS-300

DN	40	50	65	80	100	125	150	200	250	300*	400*	500*	600*
NPS	1 ½	2	2 ½	3	4	5	6	8	10	12	16	20	24
L	229	267	292	318	356	401	444	559	622	711	864	1016	1346
L1	229	267	292	318	356	401	444	559	622	711	----	----	----
L2	242	283	308	334	372	417	460	575	638	727	880	1035	1368
kD	155	165	190	210	255	280	320	380	445	520	650	775	915
T	19.1	20.7	23.9	27	30.2	33.4	35	39.7	46.1	49.3	55.6	62	68.3
K(PCD)	114.3	127	149.3	168.1	200.1	234.9	269.7	330.2	387.3	450.8	511.5	685.8	812.8
n	04	08	08	08	08	08	12	12	16	16	20	24	24
kd	22.3	19.1	22.3	22.3	22.3	22.3	22.3	25.4	28.6	31.8	34.9	35	41.3
~H(Close)	360	400	420	515	590	680	680	820	835	1000	----	----	----
~H(Open)	370	413	436	535	615	711	718	870	898	1075	----	----	----
~H1	-	-	-	-	-	-	-	-	-	1460	1639	2084	-
kHW	216	216	254	254	356	406	457	508	559	864	----	----	----
Aprox.wt.â	26	37.5	60	68.5	103	164	221	318	572	679	----	----	----

NOTE: The above data is subject to change without notice due to our continuing product improvement program. (©WEIGHT GIVEN IN KGS)

RTJ Face to Face as per ASME B16.10 Standard. Flanges upto 24" as per ASME B16.5. Butt Weld Ends as per ANSI B 16.25.

*For Gear Operated Valve



*All dimensions in mm

DIMENSIONAL DATA CLASS-600

DN	50	65	80	100	125	150*	200*	250*	300*	400*
NPS	2	2 ½	3	4	5	6	8	10	12	16
L	292	330	356	432	508	559	660	787	838.2	1194
L1	292	330	356	432	508	559	660	787	838.2	1194
L2	295	330	259	435	511	562	663	790	842	1197
kD	165	190	210	275	330	355	420	510	560	685
T	25.4	28.6	31.8	38.1	44.4	47.7	55.6	63.5	66.7	76.2
K(PCD)	127	149.2	168.3	215.9	266.7	292.1	349.2	431.8	489	603.2
n	08	08	08	08	08	12	12	16	20	20
fd	19	22.2	22.2	25.4	28.6	28.6	31.8	34.9	35	41.2
~H(Close)(H1)	400	515	530	645	750	800	830	860	884	-
~H(Open)	410	528	550	670	781	-	-	-	-	-
fHW	254	305	305	457	508	599	610	650	650	-
Aprox.wt. ã	42.5	66	88	164.5	-	340	495	834	996.	750 -

DIMENSIONAL DATA CLASS-900

DN	50	80	100	150*	200*	250*	300*
NPS	2	3	4	6	8	10	12
L	368	381	457.5	610	736.6	838	965
L1	368	281	457.5	610	736.6	838	965
L2	371	384	461	613	740	841	968
kD	215	240	290	380	470	545	610
T	38.1	38.1	44.5	55.6	63.5	69.9	79.4
K(PCD)	165.1	190.5	234.5	317.5	393.7	469.9	533.4
n	08	08	08	12	12	16	20
kd	25.4	25.4	31.8	31.8	38.1	38.1	38.1
~H(Close) (H1)	620	690	840	1145	1145	1300	1400
~H(Open)	633	810	865	-	-	-	-
kHW	300	300	400	450	450	450	450
Aprox.wt. ã	105.2	162	218	603	930	1360	1960

DIMENSIONAL DATA CLASS-1500

DN	50	65	80*	100*	150*	200*	250*	300*
NPS	2	2 ½	3	4	6	8	10	12
L	368	419	470	546	705	832	991	1130
L1	368	419	470	546	705	832	991	1130
L2	371	422	473	549	711	842	1001	1146
kD	215	145	265	310	345	485	585	670
T	38.1	41.3	47.7	54	82.6	92.1	108	123.9
K(PCD)	165.1	203.2	203.2	241.3	317.5	393.7	482.6	571.5
n	08	08	08	08	12	12	12	16
fd	25.4	31.8	31.8	35	38.1	44.5	50.8	53.8
~H(Close)(H1)	610	660	970	1140	1700	1690	1800	2200
~H(Open)	624	678	-	-	-	-	-	-
fHW	300	350	450	450	450	450	700	700
Aprox.wt. ã	42	98	148.2	174.5	517	1245	3068.3	1701.4

NOTE: The above data is subject to change without notice due to our continuing product improvement program. (©WEIGHT GIVEN IN KGS)

*For Gear Operated Valve - Flanges upto 24" as per ASME B16.5. Butt Weld Ends as per ANSI B 16.25. H1 for gear operated valves.

TEST PRESSURES

CLASS	SHELL TEST (HYDROSTATIC)		SEAT TEST			
			HYDROSTATIC		PNEUMATIC	
150	30 Bar	435 Psi g	22 Bar	319 Psi g	6.9 bar	100 Psi g
300	77 Bar	1102 Psi g	57 Bar	780 Psi g	6.9 bar	100 Psi g
600	154 Bar	2175 Psi g	113 Bar	1595 Psi g	6.9 bar	100 Psi g
900	230 Bar	3350 Psi g	169 Bar	2451 Psi g	6.9 bar	100 Psi g
1500	384 Bar	5568 Psi g	282 Bar	4075 Psi g	6.9 bar	100 Psi g

CAST STEEL GLOBE VALVES PRESSURE SEAL BONNET OS & YOKE TYPE RISING STEM BUTT WELD/FLANGED ENDS ASME B16.34

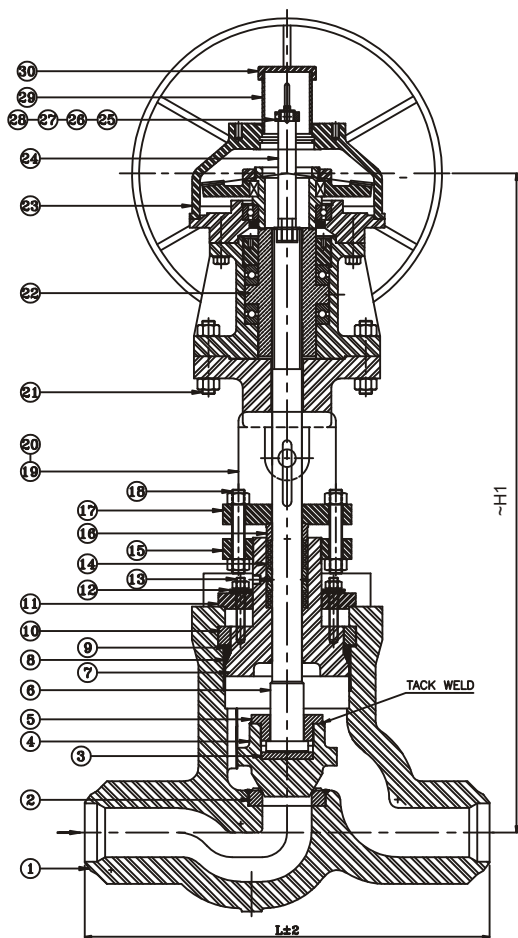

STANDARD MATERIAL COMBINATION

P. No	PART NAME	Carbon steel to ASTM		Alloy steel to ASTM					Stainless steel to ASTM			
		Type WCB	Type LCB	Type WC1	Type WC6	Type WC9	Type C5	Type C12	Type CF8	Type CF8M	Type CF3	Type CF3M
1	BODY	A216 WCB	A352 LCB	A217 WC1	A217 WC6	A217 WC9	A217 C5	A217 C12	A351 CF8	A351 CF8M	A351 CF3	A351 CF3M
2	BODY SEAT RING	As per Trim Material Combination										
3	THRUST PLATE	HARDENED STEEL										
4	DISC	As per Trim Material Combination										
5	DISC NUT	A182 F6a	F304	A182 F6a	A182 F6a	A182 F6a	A182 F6a	A182 F6a	A276 F304	A182 F316	A182 304L	A182 316L
6	STEM	As per Trim Material Combination										
7	BONNET	A216 WCB	A352 LCB	A217 WC1	A217 WC6	A217 WC9	A217 C5	A217 C12	A351 CF8	A351 CF8M	A351 CF3	A351 CF3M
8	PRESSURE SEAL GASKET	GRAPHITE										
9	PRESSURE RING	A216 WCB	A352 LCB	A217WC1	A217WC6	A217 WC9	A217 C5	A217 C12	A351 CF8	A351 CF8M	A351 CF3	A351 CF3M
10	SEGMENTED RING	A216 WCB	A352 LCB	A217WC1	A217WC6	A217 WC9	A217 C5	A217 C12	A351 CF8	A351 CF8M	A351 CF3	A351 CF3M
11	BONNET RETAINING PLATE	A216 WCB	A352 LCB	A217WC1	A217WC6	A217 WC9	A217 C5	A217 C12	A315 CF8	A351 CF8M	A351 CF3	A351 CF3M
12	BELLEVILLE WASHER	Blackened Steel										
13	BODY BONNET STUDS & NUTS	A193 B7 A194 2H	A320 L7 A194 4	A193 B7 A194 2H	A193 B16 A194 4	A193 B16 A194 4	A193 B16 A194 4	A193 B16 A194 4	A193 B8 A194 8	A193 B8 A194 8M	A193 B8 A194 8	A193 B8 A194 8M



Cast Steel Globe Valves Pressure Seal Bonnet OS & Yoke Type Rising Stem Butt Weld/Flanged Ends ASME B16.34

14	GLAND PACKING	FLEXIBLE GRAPHITE										
15	CLAMP	A216 WCB	A352 LCB	A217 WC1	A217WC6	A217WC9	A217 C5	A217 C12	A351 CF8	CF8M	CF3	CF3M
16	GLAND FOLLOWER	A182 F6a	A182 F6a	A182 F6a	A182 F6a	A182 F6a	A182 F6a	A182 F6a	A276 F304	A182 F316	A182 304L	A182 316L
17	GLAND FLANGE	A216 WCB	A352 LCB	A217 WC1	A217WC6	A217WC9	A217 C5	A217 C12	A351 CF8	CF8M	CF3	CF3M
18	GLAND STUDS & NUTS	A193 B7 A194 2H	A320 L7 A194 Gr.4	A193 B7 A194 2H	A193 B16 A194 Gr.4	A193 B16 A194 Gr.4	A193 B16 A194 Gr.4	A193 B16 A194 Gr.4	A193 B8 A194Gr.8	A193 B8 A194 Gr.8	A193 B8 A194 Gr.8	A193 B8 A194 Gr.8
19	YOKE	A216 WCB	A352 LCB	A217 WC1	A217WC6	A217WC9	A217 C5	A217 C12	A351 CF8	CF8M	CF3	CF3M
20	YOKE STUD & NUT	A193 B7 A194 2H	A320 L7 A194 Gr.4	A193 B7 A194 2H	A193 B16 A194 Gr.4	A193 B16 A194 Gr.4	A193 B16 A194 Gr.4	A193 B16 A194 Gr.4	A193 B8 A194Gr.8	A193 B8 A194 Gr.8	A193 B8 A194 Gr.8	A193 B8 A194 Gr.8
22	YOKE SLEEVE	Al. Bronze BS 1982 CC331G or Ni-resist to A4390D2										
23	YOKE	A216 WCB	A352 LCB	A217 WC1	A217WC6	A217WC9	A217 C5	A217 C12	A351 CF8	CF8M	CF3	CF3M
27	WASHER	STEEL										
29	PIPE	CARBON STEEL										
30	CAP	CARBON STEEL										

NOTE: The above data is subject to change without notice due to our continuing product improvement program.

TRIM MATERIAL COMBINATION (ON REQUEST)

Trim No.	Seat Ring Face	Wedge Seat Face	Stem	Backseat Bush	Lantern Ring
1	F6a/13%Cr.	F6a/13%Cr.	F6a/AISI410	F6a/AISI410	F6a/AISI410
2	F304	F304	F304/AISI304	F304/AISI304	F304/AISI304
5	STELLITE	STELLITE	F6a/AISI410	F6a/AISI410	F6a/AISI410
8	STELLITE	F6a/13%Cr.	F6a/AISI410	F6a/AISI410	F6a/AISI410
9	MONEL	MONEL	MONEL	MONEL	MONEL
10	F316	F316	F316/AISI316	F316/AISI316	F316/AISI316
12	316+STELLITE	316	F316/AISI316	F316/AISI316	F316/AISI316
13	ALLOY 20	ALLOY 20	ALLOY 20	ALLOY 20	ALLOY 20

NOTE: Other Trim Combination of API 600 Can Be Provided on Request. Lantern Ring Can Be Provided If Required Except For CI-150.

•All dimensions in mm

DIMENSIONAL DATA CLASS-900

DN	50	80	100	150*	200*	250*	300*
NPS	2	3	4	6	8	10	12
L	368	381	457.5	610	736.6	838	965
L1	368	281	457.5	610	736.6	838	965
L2	371	384	461	613	740	841	968
kD	215	240	290	380	470	545	610
T	38.1	38.1	44.5	55.6	63.5	69.9	79.4
K(PCD)	165.1	190.5	234.5	317.5	393.7	469.9	533.4
n	08	08	08	12	12	16	20
kd	25.4	25.4	31.8	31.8	38.1	38.1	38.1
~H(Close)(H1)	620	690	840	1145	1145	1300	1400
~H(Open)	633	810	865	-	-	-	-
kHW	300	300	400	450	450	450	450
Aprox.wt. â	105.2	162	218	603	930	1360	1960



Cast Steel Globe Valves Pressure Seal Bonnet OS & Yoke Type Rising Stem Butt Weld/Flanged Ends ASME B16.34

All dimensions in mm

DIMENSIONAL DATA CLASS-1500

DN	50	65	80*	100*	150*	200*	250*	300*
NPS	2	2 ½	3	4	6	8	10	12
L	368	419	470	546	705	832	991	1130
L1	368	419	470	546	705	832	991	1130
L2	371	422	473	549	711	842	1001	1146
kD	215	145	265	310	345	485	585	670
T	38.1	41.3	47.7	54	82.6	92.1	108	123.9
K(PCD)	165.1	203.2	203.2	241.3	317.5	393.7	482.6	571.5
n	08	08	08	08	12	12	12	16
fd	25.4	31.8	31.8	35	38.1	44.5	50.8	53.8
~H(Open)(H1)	610	660	970	1140	1700	1690	1800	2200
~H(Close)	624	678	-	-	-	-	-	-
fHW	300	350	450	450	450	450	700	700
Aprox.wt. à	42	98	148.2	174.5	517	1245	3068.3	1701.4

DIMENSIONAL DATA CLASS-2500

DN	50	65	80*	100*	150*	200*
NPS	2	2 ½	3	4	6	8
L	451	508	578	673	914	1022
L1	451	508	578	673	914	1022
L2	454	511	581	677	918	1027
kD	235	265	305	355	485	550
T	50.9	57.2	66.7	76.2	108	165.1
K(PCD)	171.5	196.6	228.6	273	368.3	438.2
n	08	08	08	08	08	12
kd	28.5	31.8	35.1	41.2	53.9	53.9
~H(Close)(H1)	610	650	750	850	1100	1300
~H(Open)	625	666	-	-	-	-
fHW	350	350	450	450	700	700
Aprox.wt. à	116	178.5	241	665	1025	1499.5

NOTE: The above data is subject to change without notice due to our continuing product improvement program. (©WEIGHT GIVEN IN KGS)

*For Gear Operated Valves. - Flanges as per ASME B16.5. Butt Weld Ends as per ANSI B 16.25. H1 for gear operated valves.

TEST PRESSURES

CLASS	SHELL TEST (HYDROSTATIC)		SEAT TEST			
			HYDROSTATIC		PNEUMATIC	
900	230 Bar	3350 Psi g	169 Bar	2451 Psi g	6.9 bar	100 Psi g
1500	384 Bar	5568 Psi g	282 Bar	4075 Psi g	6.9 bar	100 Psi g
2500	639 Bar	9372 Psi g	469 Bar	6785 Psi g	6.9 bar	100 Psi g

CAST STEEL GLOBE VALVES BS: 5160/DIN: 2401

SPECIFICATIONS

BOLTED BONNET, RISING STEM, S.S. TRIM, FLANGES AS PER DIN STD 2545 : PN 40 (R)

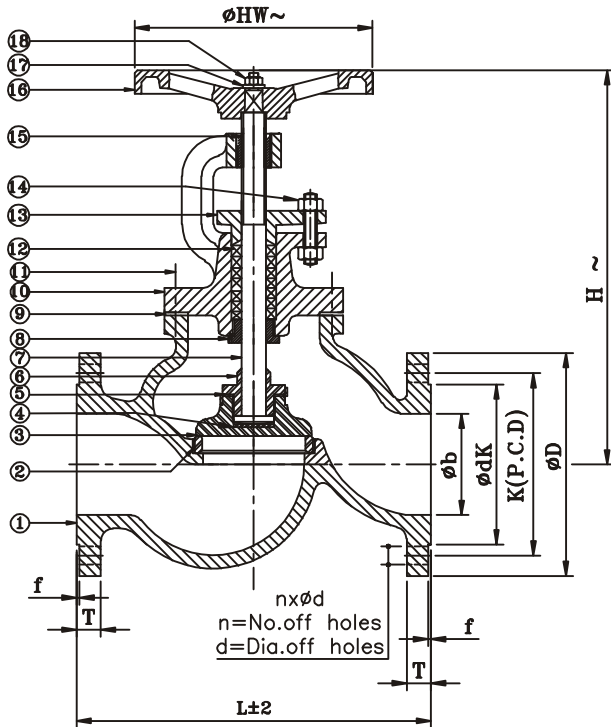

STANDARD MATERIAL COMBINATION

P.NO.	DESCRIPTION	MATERIALS	SPECIFICATIONS
1.	BODY	C.C.S.	ASTM A216 Gr.WCB
2.	BODY SEAT RING (HB-250 Min)	13% Cr. STEEL	ASTM 1 182:01 Gr. F6a
3.	DISC (HB-300 Min)	C.C.S.	ASTM A216 Gr.WCB 13% Cr. WELD DEPOSIT
4.	THRUST PLATE	HARDENED STEEL	-----
5.	LOCKING WASHER	S.S.	ANY GRADE
6.	DISC NUT (HB-250 Min)	13% Cr. STEEL	ASTM A276 TYPE410/ASTM A 182 Gr. F6a
7.	STEM (HB-200 Min)	13% Cr. STEEL	ASTM A276 TYPE410/ASTM A 182 Gr. F6a
8.	BACK SEAT BUSH (HB-250 Min)	13% Cr. STEEL	ASTM A276 TYPE410/ASTM A 182 Gr. F6a
9.	GASKET	SPRIAL WOUND S.S.304 WITH GRAPHITE FILLER	
10.	BONNET	C.C.S.	ASTM A216 Gr.WCB
11.	STUDS & NUTS	ALLOY STEEL/H.T.STEEL	ASTM A 193 GR. B7/ ASTM A 194 Gr.2H
12.	PACKING		FLEXIBLE GRAPHITE
13.	GLAND	C.C.S.	ASTM A216 Gr.WCB
14.	STUDS & NUTS	ALLOY STEEL/H.T.STEEL	ASTM A 193 Gr.B7/ ASTM A 194 Gr.2H
15.	YOKE BUSH	AL. BRONZE	BSEN 1982 Gr. CC333G
16.	HAND WHEEL	D.I.	ASTM A536 Gr. 80-55-06
17.	WASHER	CARBON STEEL	IS 2062 Gr.A
18.	NUT FOR HANDWHEEL	CARBON STEEL	BS 916-53

NOTE: The above data is subject to change without notice due to our continuing product improvement program.

CAST STEEL GLOBE VALVES BS: 5160/DIN: 2401

SPECIFICATIONS

BOLTED BONNET, RISING STEM, S.S. TRIM, FLANGES AS PER DIN STD 2545 : PN 40 (R)

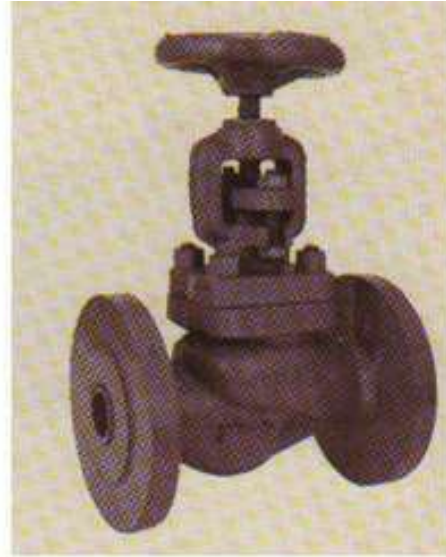
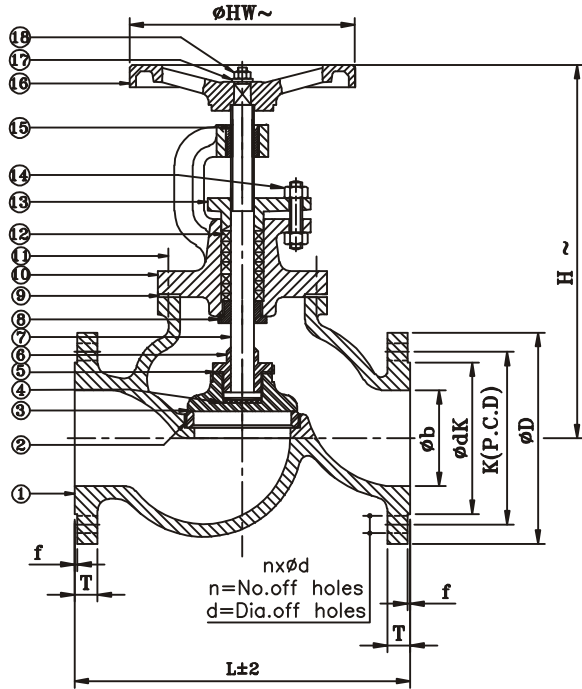

•All dimensions in mm

PRESSURE / TEMPERATURE RATINGS TO BS 5160/DIN 2401

NOMINAL PRESSURE	MAX. PERMISSIBLE GAUGE WORKING PRESSURE °C						
	10 TO 120°C	200°C	250°C	300 °C	350 °C	400 °C	425 °C
PN 40	40 bar	40bar	38bar	33bar	28bar	23bar	20bar

DIMENSIONAL DATA

DN NPS	15 1/2'	20 3/4"	25 1"	32 1-1/4"	40 1-1/2"	50 2"	65 2-1/2"	80 3"	100 4"	125 5"	150 6"	200 8"	250 10"	300 12"
ÆHW~	125	125	160	160	200	200	250	250	300	300	300	350	400	400
L	130	150	160	180	200	230	290	310	350	400	480	600	730	850
Æb	15	20	25	32	40	50	65	80	100	125	150	200	250	300
ÆD	95	105	115	140	150	165	185	200	235	270	300	375	450	515
~H(Close)	190	196	225	236	291	314	325	380	435	468	555	645	-	-
~H(Open)	194	201	231	244	301	327	341	400	460	499	593	695	-	-
dk	45	58	68	78	88	102	122	138	162	188	218	285	345	410
K	65	75	85	100	110	125	145	160	190	220	250	320	385	450
n	4	4	4	4	4	4	8	8	8	8	8	12	12	16
Æd	14	14	14	18	18	18	18	18	22	26	26	30	33	33
Aprox. Wt.©	3.23	4.85	6.35	11.7	14	20.3	32.8	42.5	66.5	105.7	169.3	268	419	660

TEST PRESSURES

NOMINAL PRESSURE RATING	SHELL TEST (HYDROSTATIC)	SEAT TEST (HYDROSTATIC & 6:9 BAR (AIR))
PN 40	60 bar	40 bar

NOTE: The above data is subject to change without notice due to our continuing product improvement program.

CAST STEEL GLOBE VALVES BS: 5160/DIN: 2401

SPECIFICATIONS

BOILED BONNET, O/S & YOKE TYPE, RISING STEM, S.S. TRIM, FLANGES AS PER DIN STD 2545 PN 40 (R.F.)

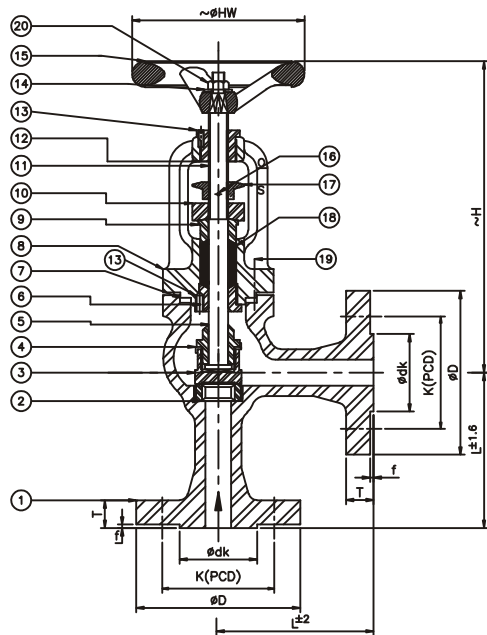

STANDARD MATERIAL COMBINATION

P.NO.	DESCRIPTION	MATERIALS	SPECIFICATIONS
1.	BODY	C.S.	ASTM A216 Gr. WCB
2.	BODY SEAT RING (HB 250 MIN)	13% Cr. STEEL	ASTM A182 Gr. F6a OR its Eq.
3.	DISC (HB 300MIN.)	S.S.(UP TO SIZE 50mm) C.S. (For Size 65mm & ABOVE)	ASTMA 182 Gr.F6a ASTMA 216 Gr.WCB 13% Cr. Weld deposit
4.	LOCKING WASHER	S.S.	-----
5.	STEM NUT (HB 250mm)	13% Cr. STEEL	ASTMA 182 Gr.F6a or its Eq.
6.	BACK SEAT BUSH	13% Cr. STEEL	ASTMA 182 Gr.F6a or its Eq.
7.	GASKET	SPIRAL WOUND STAINLESS STEEL (TYPE 304) GRAPHITE FILLER	
8.	BONNET	C.S.	ASTMA 216 Gr.WCB
9.	GLAND	13% Cr. STEEL	ASTMA 182 Gr. F6a or its Eq.
10.	GLAND FLANGE	C.S.	ASTM A216 Gr. WCB
11.	STEM (HB 200mm)	13% Cr. STEEL	ASTMA 182 Gr.F6a / ASTMA 276 TYPE410 or its Eq.
12.	YOKE BUSH	AL. BRONZE/NODULAR IRON	BS 1400-85 AB 2 C/BS 2874-84 CA 104/ ASTMA 439-83 Gr.D2
13.	GRUB SCREW	STEEL	-----
14.	WASHER	STEEL	-----
15.	HANDWHEEL	C.S./SG IRON M.I.	ASTMA 216 Gr. WCB/BS 2789 Gr.32/7/IS 2108-77 Gr. BM 290
16.	WASHER	13% Cr. STEEL	ASTMA 182 Gr.F6a or its Eq.
17.	INDICATOR	GUN METAL	BS 1400 Gr.LG2C
18.	GLAND PACKING	BRAIDED GRAPHOIL CONTAINING CORROSION INHABITOR SUITABLE FOR MAX. DESIGN TEMP. 53 8°C	
19.	STUDS & NUTS	ALLOY STEEL & H.T.STEEL	ASTM A193 Gr.B7 & ASTMA 194 Gr. 2H
20.	NUT FOR HANDWHEEL	STEEL	-----

NOTE: The above data is subject to change without notice due to our continuing product improvement program.

CAST STEEL GLOBE VALVES BS: 5160/DIN: 2401

SPECIFICATIONS

BOILED BONNET, O/S & YOKE TYPE, RISING STEM, S.S. TRIM, FLANGES as per DIN STD 2545 PN 40 (R.F.)

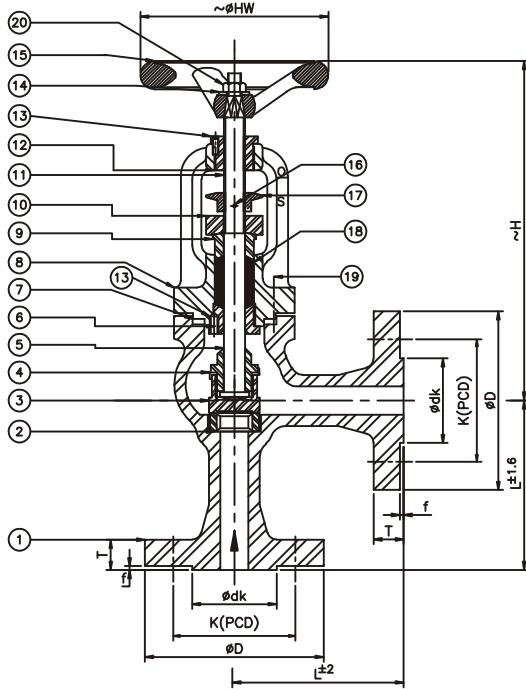

•All dimensions in mm

PRESSURE / TEMPERATURE RATINGS TO BS 5160/DIN 2401

NOMINAL PRESSURE	MAX. PERMISSIBLE GAUGE WORKING PRESSURE °C						
	10 TO 120°C	200°C	250°C	300 °C	350 °C	400 °C	425 °C
PN 40	40 bar	40bar	38bar	33bar	28bar	23bar	20bar

DIMENSIONAL DATA

DN NPS	15 1/2'	20 3/4"	25 1"	32 1-1/4"	40 1-1/2"	50 2"	65 2-1/2"	80 3"	100 4"	125 5"	150 6"	200 8"	250 10"	300 12"
L	90	95	100	105	115	125	145	155	175	200	225	275	325	375
~H(Close)	145	145	145	175	190	225	250	280	330	365	412	418	575	590
~H(Open)	149	150	151	183	200	238	266	300	355	396	450	468	638	665
HW/Æ	120	120	120	120	140	140	180	180	235	260	320	400	400	400
D/Æ	95	105	115	140	150	165	185	200	235	270	300	375	450	815
T	16	18	18	18	18	20	22	24	24	26	28	34	38	42
dk/Æ	45	58	68	78	88	102	122	138	162	188	218	285	345	410
f	2	2	2	2	3	3	3	3	3	3	3	3	3	4
k	65	75	85	100	110	125	145	160	190	220	250	320	385	450
n	4	4	4	4	4	4	8	8	8	8	8	12	12	16
d/Æ	14	14	14	18	18	18	18	18	22	26	26	30	33	33
Aprox. Wt.©	5.6	7.2	8.75	12	15.2	17.9	29.35	40.9	59.35	92.7	139.5	225	321	403

TEST PRESSURES

NOMINAL PRESSURE RATING	SHELL TEST (HYDROSTATIC)	SEAT TEST (HYDROSTATIC & 6:9 BAR (AIR))
PN 40	60 bar	40 bar

NOTE: The above data is subject to change without notice due to our continuing product improvement program.